

AN EFFICIENT HYBRIDISATION OF MULTI SOURCE ENERGY SYSTEM WITH MAXIMUM POWER POINT TRACKING

K.Somasekar, J.Pranesh Jonathan, J.Rajesh, B.Balashankar

Abstract— Environmentally friendly solutions are becoming more prominent than ever as a result of concern regarding the state of our deteriorating planet. This project presents a new system configuration of the front-end rectifier stage for a hybrid wind/photovoltaic energy system. This configuration allows the two sources to supply the load separately or simultaneously depending on the availability of the energy sources. The inherent nature of this Cuk-SEPIC fused converter, additional input filters are not necessary to filter out high frequency harmonics. Harmonic content is detrimental for the generator lifespan, heating issues, and efficiency. The structure proposed is a fusion of the buck and buck-boost converter. The systems in literature require passive input filters to remove the high frequency current harmonics injected into wind turbine generators. The harmonic content in the generator current decreases its lifespan and increases the power loss due to heating. In this project, an alternative multi-input rectifier structure is proposed for hybrid wind/solar energy systems. The proposed design is a fusion of the Cuk and SEPIC converters, modeling and analysis with the maximum power point tracking algorithm.

I. INTRODUCTION

Natural energy based power generation systems are commonly equipped with storage batteries, to regulate output fluctuations resulting from natural energy variation. Therefore, it is necessary to prevent battery overcharging. As for the utility connected hybrid generation system consists of a wind power, a solar power, and battery, the dump power is able to control to prevent overcharging the battery without dump load because of dump power transferred into the utility. The individual power generation system, it is considered that a PV system featuring low cost and simple control, which incorporates maximum power point tracking control that makes use of diode characteristics, or a PV system which features output stability with a multiple-input DC-DC converter capable of controlling the output of different power sources in combination, or a cascaded DC-DC converter PV system.

which features good efficiency along with low cost, or a wind turbine system which features output stability with a combination of an electric double-layer capacitor and storage

battery, is suitable for use with hybrid power generation systems to stabilize power supply. In contrast, the standalone hybrid system is mainly composed of natural energy sources (i.e. wind power, solar power), and a storage battery; and in some cases, a diesel engine generator may be incorporated into the system as well. However, there is a tendency that the greater the system sophistication, the more suitable the power control techniques are required to be. A DC-DC converter is mounted in both wind power and solar power generation systems.

The two systems are interconnected at the output sides of individual converters, and are also connected to the storage battery. In such a configuration, each DC-DC converter is capable of monitoring the current and voltage of the storage battery, and optimally controlling battery charging, to supply power to the load. In most cases where converters and storage batteries are setup at a centralized location, the storage batteries are commonly installed adjacent to the wind- and solar-power generation systems; therefore there is generally no freedom to install the batteries on flat ground or in places with good vehicular access for easy maintenance and replacement. In a hybrid system with a centralized inverter setup, the output of DC-DC converters is sent to an external DC-AC inverter to supply AC power to load

The topic of solar energy utilization has been looked upon by many researchers all around the globe. It has been known that solar cell operates at very low efficiency and thus a better control mechanism is required to increase the efficiency of the solar cell. In this field researchers have developed what are now called the Maximum Power Point Tracking (MPPT) algorithms. And many new converter topology design for eliminating the losses in the input side of supply end. 1. have given a detailed report on the use of a SEPIC converter in the field of photovoltaic power control. In their reports control objective is to balance the power flow from the PV module to the battery and the load such that the PV power is utilized effectively and the battery is charged with three charging stages. The effectiveness of the proposed methods is proved with some simulation using PSIM and experimental results [8]. 2. paper, two different methods are used to maximize the generated power. Thus, a comparison between the 'perturb and observe' control method and the 'incremental conductance' control method are given, analyzed and discussed [14]. 3. Paper, the intelligent controller (PI) will provide good response in steady state operation of maximum power production in the case of varying irradiation level by an different mppt control algorithm. [1] 4 paper hybrid generation system of photovoltaic and wind power, which combines wind power energy and solar energy to have effect of supporting each other. But, hybrid generation system cannot always generate stable output with weather condition.

Manuscript received Aug 22, 2014

K.Somasekar, Department of EEE, PITAM, India

J.Pranesh Jonathan, Department of EEE, PITAM, India

J.Rajesh, Department of EEE, PITAM, India

B.Balashankar, Department of EEE, PITAM, India

AN EFFICIENT HYBRIDISATION OF MULTI SOURCE ENERGY SYSTEM WITH MAXIMUM POWER POINT TRACKING

So the auxiliary generation apparatus uses elastic energy of spiral spring to hybrid generation system. [9]

II. Proposed System

Existing System

Standalone or autonomous system is not connected to the grid. Some standalone system known as pv system or island system, may also have another source of power, wind turbine, bio-fuel or diesel generator, etc. A standalone system varies in shapes and type, but 20WP-1KWP is common. The stand-alone systems are known as off grid system. A off grid system vary widely in size and application from remote areas to spacecraft. In many standalone system the battery used as storage system and charge controller used for overall control operation.

The solar and Wind sources are intermittent in nature and unable to meet the load demands. The converter topology will not supply high step up buck or boosted voltage operation. (Dc-Dc conversion is less) The stand-alone system unable to connect to grid operation. Inefficient control and no utilization of maximum power from sources.

Proposed System

In order to eliminate the problems in the stand-alone pv and wind system and meeting the load demand, The only solution to combine one or more renewable energy sources to meet the load demand. so the new proposed input side converter topology with maximum power point tracking method to meet the load and opt for grid connected load as well as commercial loads. The implementation of new converter topology will eliminate the lower order harmonics present in the hybrid power system circuit. Merits Of Proposed System

1. The maximum power can be track from the inputs solar and wind.
2. Eliminate the lower order harmonics and avoiding the filters.
3. Improved Economics
4. Increased Reliability
5. Design flexibility
6. High power quality

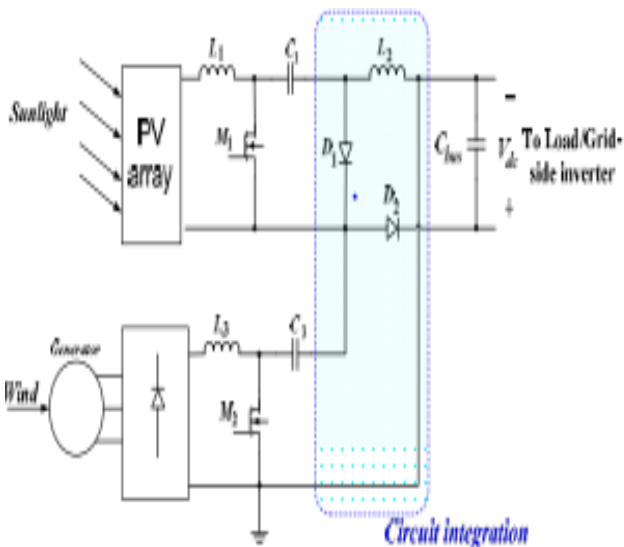

Figure 1 Circuit Diagram

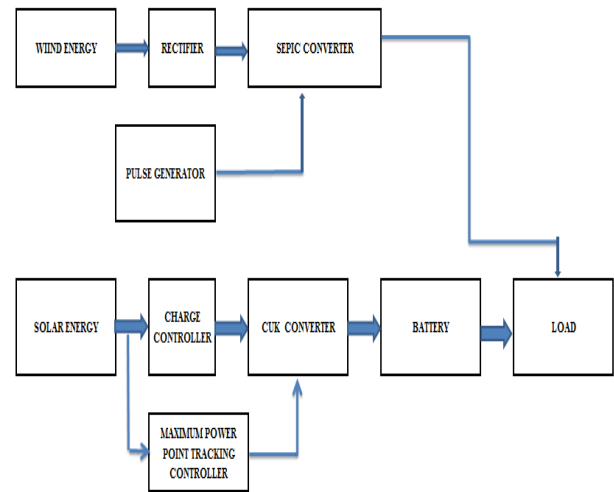

Figure 2 Block Diagram

Mode Of Operation Of The Converter Topology

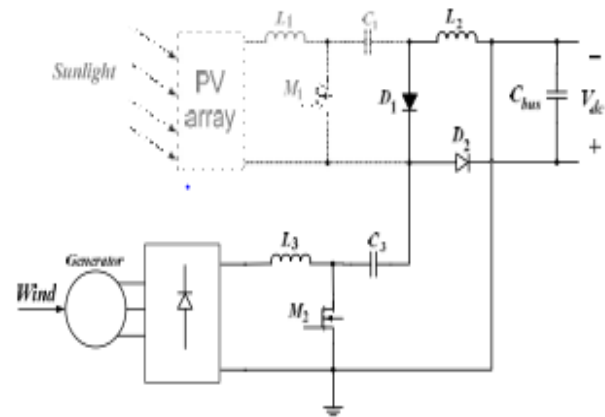

Figure 3 Mode 1: When M2 Is On And M2 Is Off (Sepic Operation)

When M2 is on condition, in the hybrid system, Wind energy will meet the load by a sepic converter operation. The wind energy will produce the Ac power, the Ac power further converted to dc power by using the rectifier. The converted dc power will stored in battery, and feed the load. Normally the sepic converter will triggered at 50% of the duty cycle to meet the load demand.

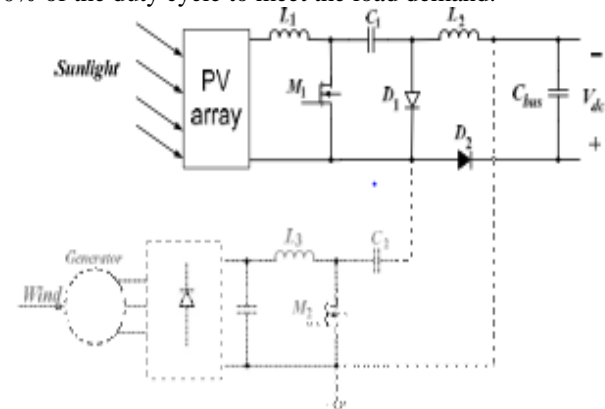

Figure 4 Mode: When M1 Is On And M2 Is Off (Cuk Operation)

When M1 is on condition, in the hybrid system, solar energy will meet the load by a cuk converter operation. The solar energy will produce the dc power; the dc power will stored in battery, and feed the load. Normally the sepic converter will triggered at 50% of the duty cycle by using the maximum power point tracking controller to meet the load demand. The maximum power point tracking controller which contains the maximum power point algorithm for varying the duty cycle D .In this project deals with the perturb and observation algorithm for varying duty cycle by using the voltage and current as reference.

III. MAXIMUM POWER POINT TRACKING MODELING

Because of the photo voltaic nature of solar panels, the I–V Curves depend nonlinearly on temperature and irradiate levels. Therefore, the operating current and voltage, which maximized power output, will change with environmental conditions. In order to maintain efficient operation despite environmental variations, one approach is to use a Maximum Power Point Tracking (MPPT) algorithm [7] to dynamically tune either control current or voltage to the maximum power operating point. Various methods of MPPT have been considered in the applications of solar arrays. MPPT is a algorithm that included in charge controllers used for extracting maximum available power from PV module under certain conditions. The voltage at which PV module can produce maximum power is called ‘maximum power point’ (or peak power voltage). Maximum power varies with solar radiation, ambient temperature and solar cell temperature. The major principle of MPPT is to extract the maximum available power from PV module by making them operate at the most efficient voltage.

Perturb and observe method

Perturb & Observe (P&O) is the simplest method. In this we use only one sensor, that is the voltage sensor, to sense the PV array voltage and so the cost of implementation is less and hence easy to implement. The time complexity of this algorithm is very less but on reaching very close to the MPP it doesn't stop at the MPP and keeps on perturbing on both the directions. When this happens the algorithm has reached very close to the MPP and we can set an appropriate error limit or can use a wait function which ends up increasing the time complexity of the algorithm. However the method does not take account of the rapid change of irradiation level (due to which MPPT changes) and considers it as a change in MPP due to perturbation and ends up calculating the wrong MPP. To avoid this problem we can use incremental conductance method [9].

Incremental Conductance Method

Incremental conductance method uses two voltage and current sensors to sense the output voltage and current of the PV array. At MPP the slope of the PV curve is 0.

$$\left(\frac{dp}{dv}\right)_{MPP} = \frac{d(VI)}{dV}$$

$$0 = I + \frac{v dI}{dV}_{MPP}$$

$$\frac{dI}{dV}_{MPP} = -I/V$$

The left hand side is the instantaneous conductance of the solar panel. When this instantaneous conductance

equals the conductance of the solar then MPP is reached. Here we are sensing both the voltage and current simultaneously. Hence the error due to change in irradiance is eliminated. However the complexity and the cost of implementation increase [9].

Constant Voltage method

This method which is a not so widely used method because of the losses during operation is dependent on the relation between the open circuit voltage and the maximum power point voltage. The ratio of these two voltages is generally constant for a solar cell, roughly around 0.76. Thus the open circuit voltage is obtained experimentally and the operating voltage is adjusted to 76% of this value.

Constant Current Method

Similar to the constant voltage method, this method is dependent on the relation between the open circuit current and the maximum power point current. The ratio of these two currents is generally constant for a solar cell, roughly around 0.95. Thus the short circuit current is obtained experimentally and the operating current is adjusted to 95% of this value.

Owing to its simplicity of implementation we have chosen the Perturb & Observe algorithm for our study among the two.

Perturb & Observe Algorithm

The Perturb & Observe algorithm states that when the operating voltage of the PV panel is perturbed by a small increment, if the resulting changes in power ΔP is positive, then we are going in the direction of MPP and we keep on perturbing in the same direction. If ΔP is negative, we are going away from the direction of MPP and the sign of perturbation supplied has to be changed [9].

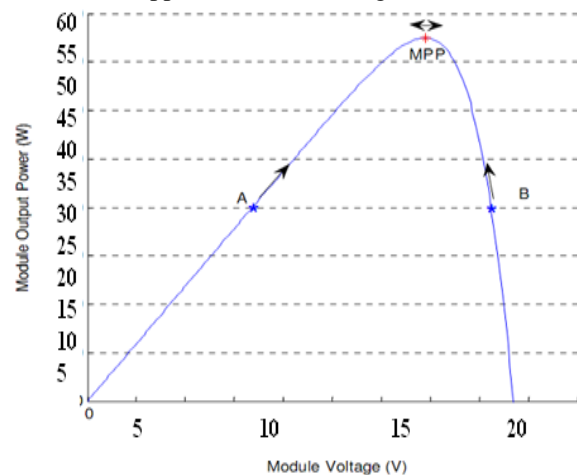

Figure 6 MPP Tracking using P & O Algorithm

Figure shows the plot of module output power versus module voltage for a solar panel at a given irradiation. The point marked as MPP is the Maximum Power Point, the theoretical maximum output obtainable from the PV panel. As shown in the figure above, Consider A and B as two operating points the point A is on the left hand side of the MPP. Therefore, we can move towards the MPP by providing a positive perturbation to the voltage. On the other hand, point B is on the right hand side of the MPP. When we give a positive perturbation, the value of ΔP becomes negative, thus it is imperative to change the direction of perturbation to achieve MPP. The flowchart for the P&O algorithm [9] is shown in Figure

AN EFFICIENT HYBRIDISATION OF MULTI SOURCE ENERGY SYSTEM WITH MAXIMUM POWER POINT TRACKING

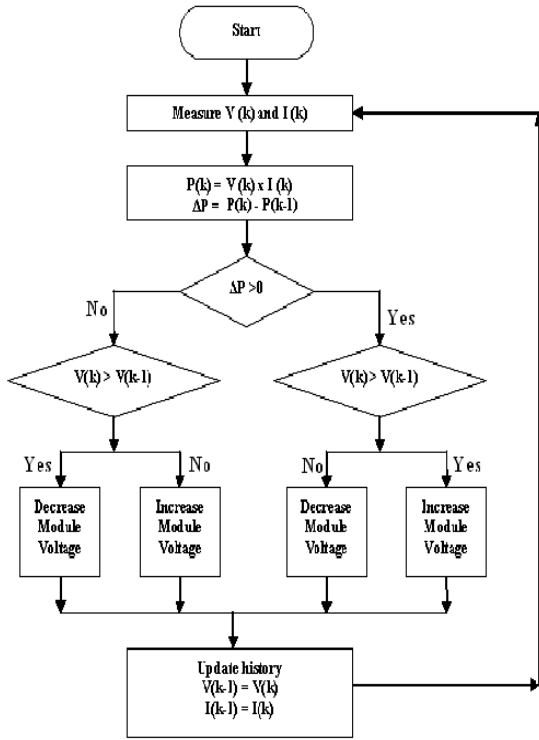

Figure 7 Flowchart of P&O Algorithm

IV. SIMULATION MODEL AND RESULTS

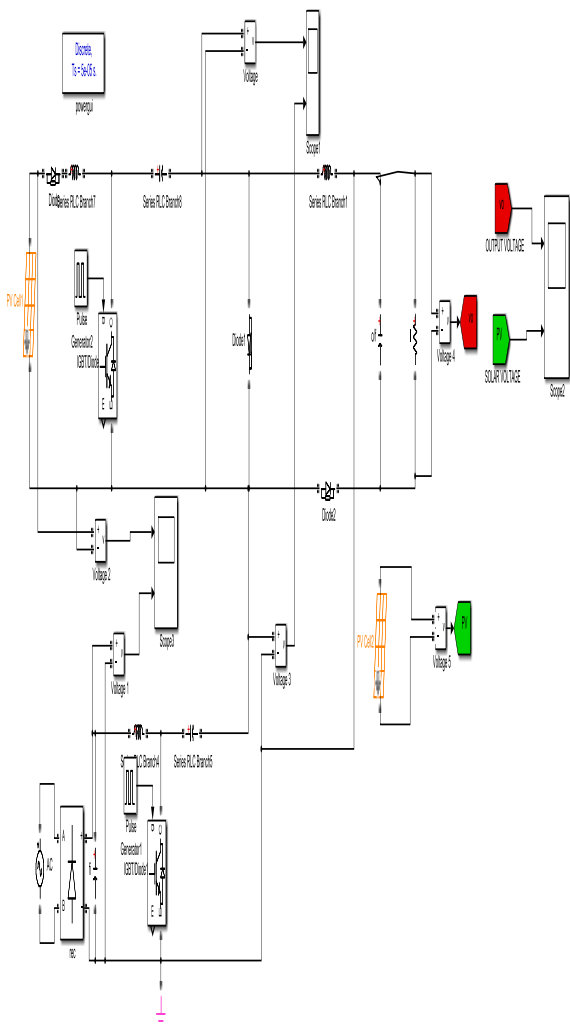

Figure 8 Open Loop Model

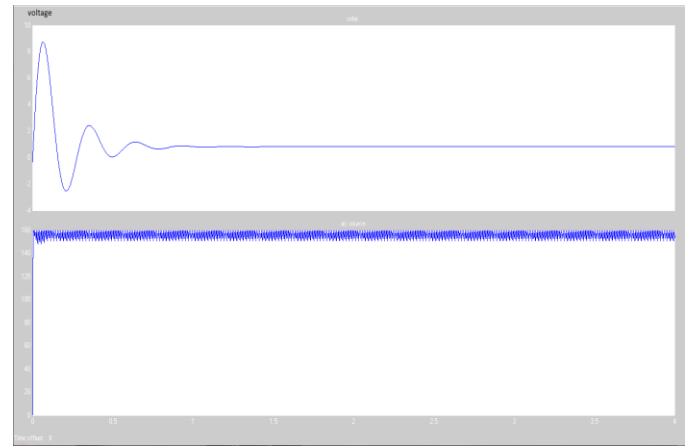

Figure 9 Input Voltages Of Solar And Wind Source

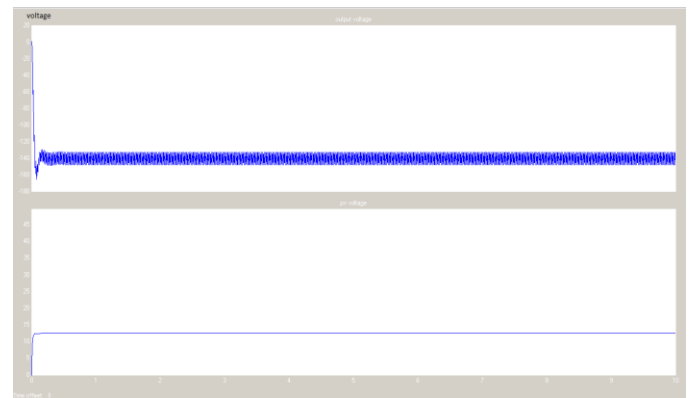

Figure 10 Open Loop Maximum Power Point Input And Output Voltage

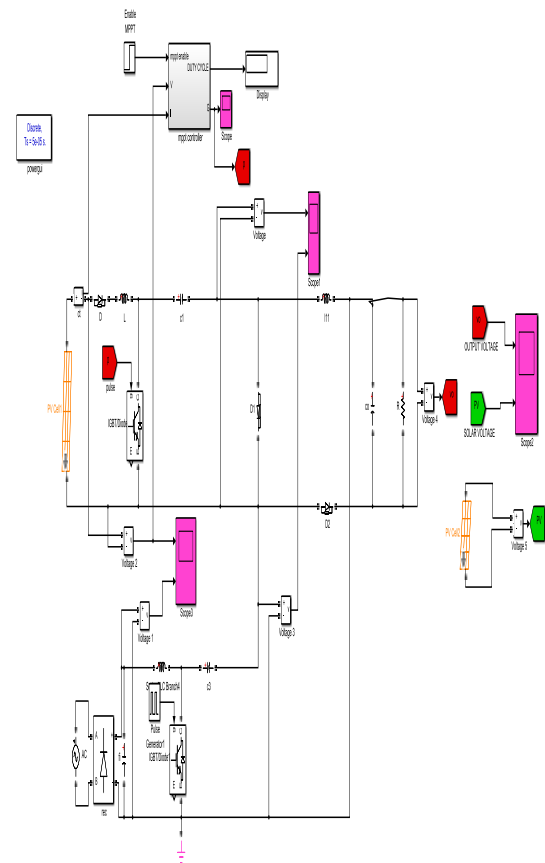

Figure 11 Closed Loop Model With Maximum Power Point Tracking

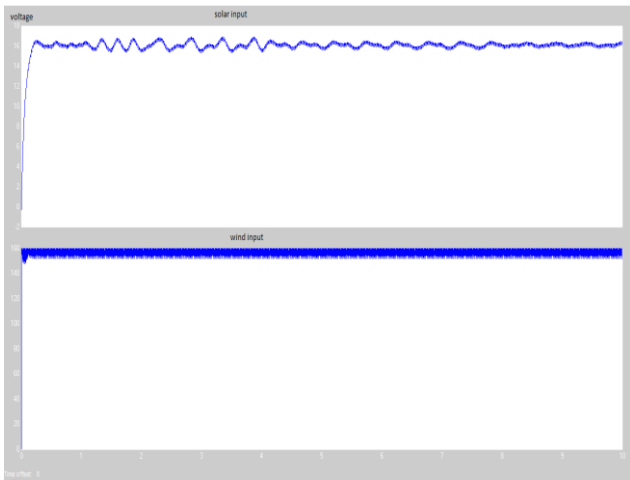

Figure 12 Closed Loop Input Voltages Of Solar And Wind

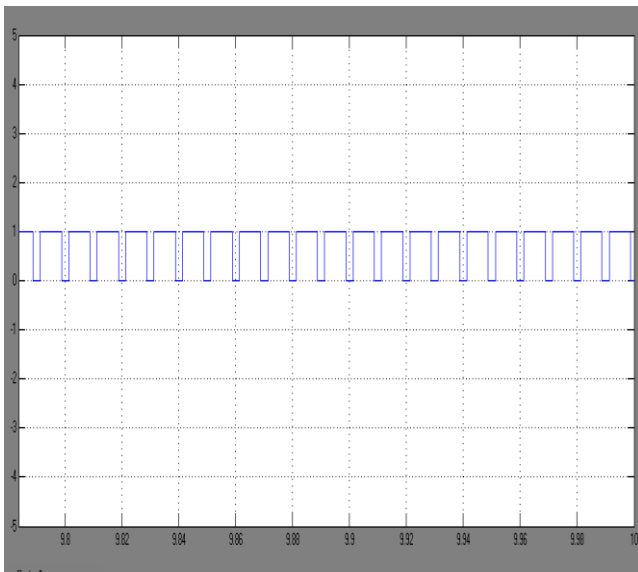

Figure 13 Pulse Generation Pattern

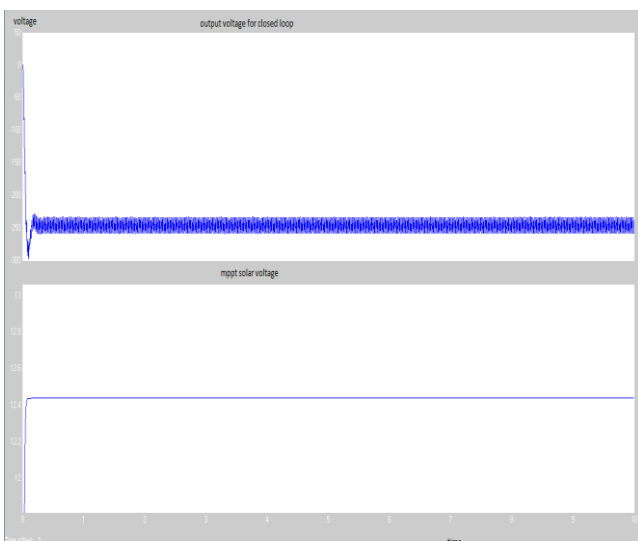

Figure 14 Closed Loop Output with Maximum Power Point Input And Output Waveform

Conclusion

In this project a new multi-input Cuk-SEPIC rectifier stage for hybrid wind/solar energy systems has been presented. The features of this circuit are 1) Additional input filters are not necessary to filter out high frequency harmonics;2) Both

renewable sources can be stepped up/down (supports wide ranges of PV & wind 3) MPPT can be realized for each source;4) Individual and simultaneous operation is supported. Simulation results have been presented to verify the features of the proposed topology. And the proposed an efficient hybridisation of multi-source energy system with maximum power point tracking has been successfully simulated using Mat lab/Simulink Software.

References

- [1] Belfkira. R, Hajji. O, Nichita. C, Barakat. G, "Optimal sizing of stand-alone -hybrid wind/pv system with battery storage," in Proc. Power Electronand Application. Euro. Conf., Sept. 2007.
- [2] Bonanno. F, Consoli. A, Lombardo.D and Raciti.A, "A logistical model for performance evaluations of hybrid generation systems," IEEE Transition.
- [3] Bratcu. A. I,Munteau.I, Bacha.S, Picault.D, and Raison. B, "Cascaded DC-DC converter photovoltaic systems: power optimization issues," IEEE Trans. Ind. Electron., Vol. 58, no. 2, pp.403-411, Feb. 2011.
- [4] Haruni.A. M. O, Gargoom. A, Haque.M.E, and Negnevitsky. M, "Dynamic Operation and control of a hybrid wind-diesel stand alone power systems," inProc. IEEE Applied Power Electron. Conf.(APEC2010), pp. 162-169, Feb. 2010.
- [5] K, Jeon. J. H, Cho. C. H, Ahn. J. B, Kwon. S. H, "Dynamic modeling and control of a grid-connected hybrid generation system with versatile power transfer," IEEE Trans. Ind. Electron., Vol. 55, no. 4, pp. 1677-1688, Apr. 2008
- [6] Meenakshi. S, Rajambal. K, Chellamuthu. C, and Elangovan. S, "Intelligent controller for a stand-alone hybrid generation system," in Proc.IEEE Power India Conf., 2006.
- [7] Chen Qi, Zhu Ming (2012): "Photovoltaic Module Simulink Model for a Stand-alone PV System.", physics procedia 24
- [8] Chiang.S.J, Hsin-JangShieh, Member,IEEE, and Ming-Chen: "Modeling and Control of PV Charger System With SEPIC Converter",IEEE Transactions On Industrial Electronics, Vol.56, No.11, November 2009.
- [9] Datasheet of "Design a SEPIC Converter", May-2006, National Semiconductor.
- [10] Gomathy.S, S.Saravanan, Dr. S. Thangavel, March 2012: "Design and implementation of Maximum Power Point Tracking (MPPT) Algorithm for a Standalone PV System".International Journal of Scientific & Engineering Research, Vol. 3, Issue no.3.
- [11] EftichiosKoutroulis, Kostas Kalaitzakis, Member, IEEE, and Nicholas C.Voulgaris , January 2001 : "Development of a Microcontroller-based, Photovoltaic Maximum Power Point Tracking Control System", IEEE Transactions On Power Electronics, Vol.16, no.1.
- [12] Moacyr A. G. de Brito, Luigi G. Jr., Leonardo P. Sampaio, Guilherme A. e Melo and Carlos A. Canesin, Senior Member, IEEE, 2012 : "Evaluation of the Main MPPT Techniques for Photovoltaic Applications".
- [13] Ms.Sangita S. Kondawar , U. B. Vaidya, Aug 2012: " A Comparison of Two MPPT Techniques for PV System in MATLAssB Simulink", Vol.2, no.7, PP.73-79.