

Broadband Reconfigurable Optical Add-Drop MUX Using Opto-VLSI Processor

I.Ravi Kumar, N.Bala Saraswathi

Abstract— In this paper, an Opto-VLSI based reconfigurable optical add/drop mux (ROADM) structure using two arrayed waveguide grating demux (AWGs) and a custom-made fiber array is described. The fiber array consist of N pairs of lower and upper fibers, where each pair functions as an add, a drop or a thru multiplexers depending on the hologram generated by the Opto-VLSI processor. Experimental results show that for a wide range of wavelength from 1524 nm to 1576 nm the proposed ROADM structure has an average insertion loss of 5.5 dB for all the functions and a uniformity of 0.3 dB. A low drop/thru crosstalk levels of around -40 dB is also depicted.

Index Terms— ROADM, Opto-VLSI, Add-Drop Mux, DWDM, fiber, waveguide grating, Mux

I. INTRODUCTION

To increase the channel capacity of the fiber optics network and transmission, the Dense Wavelength Division Multiplexing (DWDM) technology is being used. One attractive component that can be used to enhance the flexibility and performance of the DWDM systems is the Reconfigurable Optical Add-Drop Multiplexer (ROADM), which can dynamically add, block, pass or redirect DWDM channels. An ROADM can be used to remotely reconfigure, add and drop capacity at each network node, which allows for network upgrades without affecting in-service traffic and helps in minimizing the operation costs, especially in metro/regional environments. Hence, a ROADM has vast data traffic handling capability, and control the optical channel for optimum network performance [1, 2].

Various techniques have been proposed to realize dynamic optical add/drop multiplexing [3, 4, 5], among them are the wavelength blocker (WB) type [6], wavelength selective switch type (WSS) [7] and planar-lightwave-circuit (PLC) type [8, 9]. Each techniques has various trade-offs such as bandwidth, flexibility, channel isolation, switching times, reliability, integration and cost. The main factor that still prevents ROADMs from wide applications in optical communication networks is high implementation cost.

In this paper, a ROADM structure employing a custom fiber array, arrayed waveguide grating de/multiplexers and Opto-VLSI processors is proposed. The processors could be programmed to generate multiphase steering hologram to adaptively steer various wavelength

channels, thus achieving add, drop and WDM multiplexing. Proof-of-concept experiments demonstrate a flexible ROADM, having wide bandwidth, large wavelength numbers, good channel isolation, and with relatively simple structure.

II. PROPOSED STRUCTURE

A. Opto-VLSI Processor

An Opto-VLSI processor is an array of liquid crystal (LC) cells driven by a VLSI circuit. The processor is electronically controlled, software configurable, polarization independent, and very reliable since beam steering is achieved with no mechanically moving part. The diffraction angle for the Opto-VLSI processor α_m , is given by [10]:

$$\alpha_m = \text{arc sin} (m\lambda/d) \dots\dots\dots(1)$$

where m is the diffracted order (only the first order is considered), λ is the vacuum wavelength, and d is the grating period.

The Opto-VLSI processor is used to generate reconfigurable reflective holographic diffraction gratings to steer and/or shape optical beams in the proposed ROADM structure.

B. ROADM Architecture

Fig.1 shows the structure of the proposed reconfigurable optical add-drop multiplexer. The WDM signals launched at the input-port are routed to an N-channel arrayed waveguide grating demultiplexer (AWG1) by using a circulator. Each output port is assigned to a wavelength channel (from λ_1 to λ_N), and each port is connected to a corresponding fiber in the optical fiber array. The fiber array consists of N-fiber pairs; each pair consists of an upper fiber (connected to AWG1) and a lower fiber (connected to AWG2). The angle between the lower and upper fibers is θ ; it is selected to minimize the insertion loss and crosstalk. A lens array is used to collimate the divergent beams from the upper optical fibers, and the collimated beams are projected to illuminate different pixel blocks on the Opto-VLSI active window. The Opto-VLSI processor is tilted at an angle, ϕ , with respect to the lens array. When a blank hologram is used, the collimated beam from an upper optical fiber is placed in such a way so that the reflection from the Opto-VLSI falls onto the area between the lower and upper optical fiber pairs.

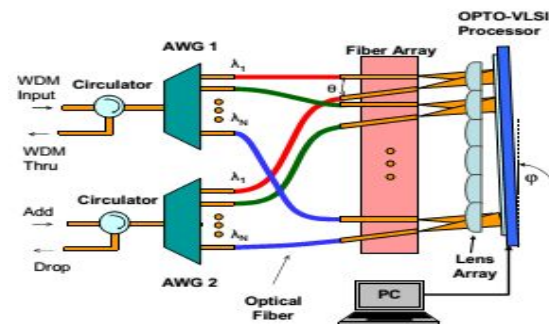

Manuscript received Dec 06, 2014

I.Ravi Kumar, Department of ECE, SVITS, Mahabubnagar, India.

N.Bala Saraswathi, Department of ECE, TCET, Vandhavashi, India

Fig. 1. Proposed ROADM Structure Using Opto-VLSI Processor, AWGs, Custom-made Fiber Array for Optical Beam Steering.

By applying an appropriate hologram into the Opto-VLSI processor, each collimated beam could be independently steered and coupled to either back to the upper fiber (for thru operation) or routed to the lower fiber (for drop operation). All dropped wavelengths are multiplexed via AWG2 and sent to the drop-port through a circulator. The added wavelengths launched at the add-port propagate along the same paths of the dropped wavelengths but in the opposite directions, where they are steered by the Opto-VLSI processor, coupled to the upper fibers and multiplexed via AWG1 to reach the thru port. The 1-D ROADM structure shown in Fig. 1 could easily be extended to a 2-D structure by using a 2-D large-area Opto-VLSI processor in conjunction with a 2-D custom fiber array, and a 2-D micro lens array. This decreases the cost per channel and extend the capability of add, drop, and thru operation.

III. EXPERIMENTAL RESULTS

To demonstrate the principle of the ROADM, a custom-made fiber array was fabricated, and the upper and lower fiber pairs are placed with an angle. In general, the larger the angle between the fiber pairs the lower will be the crosstalk between the lower and upper fibers. But the insertion loss for the thru and add/drop operations would become larger. Therefore, by considering the trade-offs between the two parameters (loss and crosstalk), the angle between the upper and lower fibers of the custom fiber array, θ , is selected to be 1.5° .

Fig.2 shows the experimental setup, where add, drop and thru operation were evaluated. A tunable laser source with a wavelength range between 1524 nm and 1576 nm was used in the experiment.

Two optical spectral analyzers were employed to monitor for the thru-port (OSA 1) and drop-port (OSA 2), respectively. A 2 mm diameter lens with a focal length of 5 mm was used to collimate the light from the upper fiber that has 1 mm diameter, and the collimated beam was launched onto the active window of the Opto-VLSI processor. The 1-D, 256-phase-level Opto-VLSI processor used in the experiments has 1x4096 pixels with 1 mm pixel size and 0.8 mm dead spacing between adjacent pixels. A Labview software was developed to generate optimized digital holograms that steer the incident beam along desirable directions.

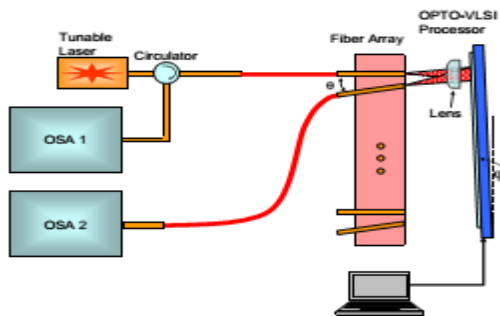

Fig 2. Experimental Setup for Demonstrating the Concept of the ROADM Structure.

When no phase hologram is applied, the Opto-VLSI processor acts as a mirror. The Opto-VLSI processor was slightly tilted at the angle ϕ , so that the reflected collimated beam is focused onto an area between the lower and upper fibers (called zeroth-order spot) when there is no hologram uploaded.

In the experiment, the zeroth-order direction has an angle of 0.6° with respect to the upper fiber, and 0.89° with respect to the lower fiber.

Two phase holograms were generated and optimized for steering and coupling the incident collimated beam to either the upper fiber for thru operation or the lower fiber for drop operation.

Fig. 3(a) and Fig. 3(b) show the spectra of the optical signals measured at the thru and drop ports, respectively, when an input optical channel of wavelength 1539 nm was reflected back to the thru port. Fig. 3(c) and Fig. 3(d) show the spectra of the optical signals measured at the thru and drop ports, respectively, when an input optical channel of wavelength 1576 nm was reflected back to the thru port. The crosstalk (defined as the optical power that is coupled into the lower fiber port when the optical beam is steered into the upper fiber port) in both steering scenarios is below -40 dB. Note that the laser power launched into the fiber array was +2 dBm. As shown in Fig. 3, the drop and thru optical power levels were from -2.9 dBm to -3.4 dBm, exhibiting a uniformity of around 0.3 dBm. Therefore, the measured insertion loss for drop/thru operation was about 5.5 dB.

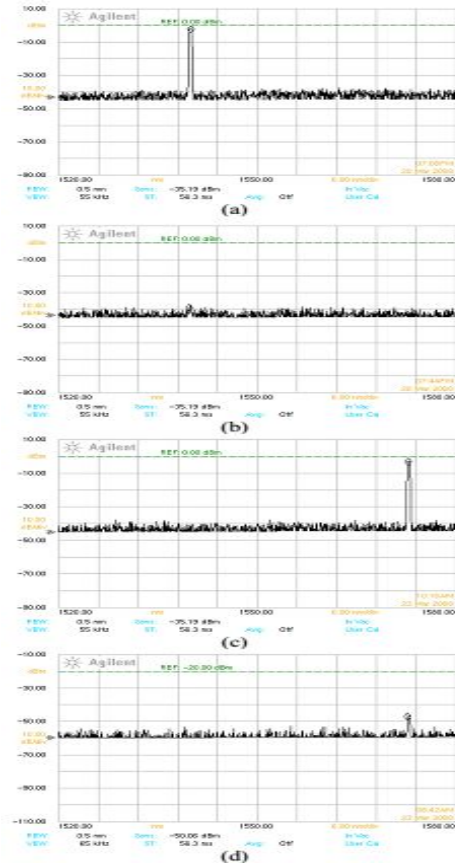

Fig.3.(a) and (c) Maximum Optical Power Coupled Back into Upper port, (b) and (d) Crosstalk at the Lower port. Input Wavelength is 1539 nm for (a) and (b), 1576 nm for (c) and (d).

Fig.4 shows the measured signal and the crosstalk levels versus wavelength, demonstrating a maximum crosstalk level below - 40 dBm.

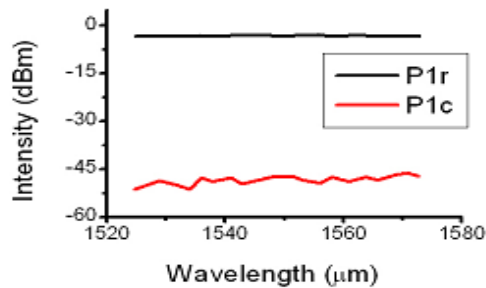

Fig.4. Power Coupled into the Upper port (P1r) when the Optical Beam is steered into the Upper port and the Cross talk at the Lower port (P1c).

This ROADM has wavelength port assignment flexibility because each wavelength channel can be routed from AWG1 via an optical fiber and mapped onto an appropriate pixel block dedicated to add or drop that particular wavelength channel. In addition, the signal levels for add, drop, and thru operation could all be balanced by simply reconfiguring the steering phase holograms of the Opto-VLSI processor. Note that, by using a 2-D Opto-VLSI processor, the number of channels could be increased significantly. For example, a 128-channel ROADM can be realized by using a 2-D 8192x8 pixel Opto VLSI processor.

CONCLUSION

An ROADM structure based on a custom fiber array and an Opto-VLSI processor has been proposed. Experimental results have shown a high drop/pass isolation level less than - 40 dB, more than 50 nm bandwidth with uniformity of ± 0.3 dB, and an insertion loss as small as 5.5 dB. The proposed ROADM structure exhibits broad bandwidth, high flexibility, high reliability, high channel isolation, cost-effectiveness, and compact size. It has the potential to meet the requirements for high optical performance in reconfigurable optical networks.

REFERENCES

- [1] M. Allen, C. Liou, S. Melle, and V. Vusirikala, "Digital optical networks using photonic integrated circuits (PICs) address the challenges of reconfigurable optical networks," *IEEE Communications Magazine* 46, 35–43(2008).
- [2] H. Zhu, and B. Mukherjee, "Online Connection Provisioning in Metro Optical WDM Networks Using Reconfigurable OADMs," *Journal of Lightwave Technology* 23, 2893–2901 (2005).
- [3] M. Muha, B. Chiang, and R. Schleicher, "MEMS Based Channelized ROADM Platform," *Proc. OFC/NFOEC* (2008).
- [4] E. J. Klein, D. H. Geuzebroek, H. Kelderman, S. Gabriel, N. Baker, and A. Driessen, "Reconfigurable optical add-drop multiplexer using microring resonators," *IEEE Photon. Technol. Lett.* 17, 2358–2360 (2005).
- [5] B. P. Keyworth, "ROADM Subsystems & Technologies," *Proc. OFC/NFOEC* (2005).
- [6] R. Ryf, Y. Su, L. Moller, S. Chandrasekhar, X. Liu, D. T. Neilson, and C. R. Giles, "Wavelength Blocking Filter with Flexible Data Rates and Channel Spacing," *Journal of Lightwave Technology*, 23, 54–61 (2005).
- [7] L. Zong, X. Huang, T. Wang, P. Ji, O. Matsuda, and M. Cvijetic, "A Novel Tunable DeMUX/MUX Solution for WSS-Based ROADM and WXC Nodes," *Proc. OFC/NFOEC* (2007).

- [8] M. P. Earnshaw, M. Cappuzzo, E. Chen, L. Gomez, A. Griffin, E. Laskowski, A. Wong-Foy, and J. Soole, "Planar lightwave circuit based reconfigurable optical add-drop multiplexer architectures and reusable subsystem module," *IEEE Journal of Selected Topics in Quantum Electronics* 11, 313–322 (2005).
- [9] L. Eldada, J. Fujita, A. Radojevic, T. Izuhara, R. Gerhardt, J. Shi, D. Pant, F. Wang, and A. Malek, "40-Channel Ultra-Low-Power Compact PLC-Based ROADM Subsystem," *Proc. OFC/NFOEC* (2006).
- [10] I. G. Manolis, T. D. Wilkinson, M. M. Redmond, and W. A. Crossland, "Reconfigurable multilevel phase holograms for optical switches," *IEEE Photon. Technol. Lett.* 14, 801–803 (2002).

I.Ravi Kumar is working as Dean and Professor in the Department of Electronics & Communication Engineering, Sree Visvesvaraya Institute of Technology & Science, Mahabubnagar, India. He has more than 13 years of experience and authored several text books in Engineering and Technology and published several papers in journals and conferences.

N.Bala Saraswathi is working as Associate Professor in the Department of Electronics & Communication Engineering, Thiruvalluvar College of Engineering & Technology, Vandhavashi, India. She has more than 13 years of experience and authored several text books in Engineering and Technology and published several papers in journals and conferences.