

Implementation of Boost H6 Inverter Using Hybrid Modulation

K.Venkata Ravindra, N.Venkateswarlu, T.Ravi Kumar

Abstract— This paper presents the design and implementation of Photovoltaic fed high performance boost H6 inverters using hybrid modulation method. In this configuration without the input split capacitors, multiple DC sources, common-mode voltage and leakage current issues can be eliminated in standalone PV system. The main objective of this system is to achieve high efficient system with the elimination of common-mode voltage and leakage current. The hybrid modulation topology is the combination of unipolar and bipolar pulse width modulation schemes. The performance of the proposed system is analyzed by comparing the level of reduction of common mode error as a parameter and the working of existing H4 inverter.

Index Terms – H4 inverter, H6 inverter, Hybrid Modulation, Common mode voltage, Leakage Current

I. INTRODUCTION

In recent years, photovoltaic (PV) systems have become more and more widespread in private and commercial applications. Nonisolated inverters with decreased number of components, low cost, and high efficiency are preferred choices for these applications, where power density, cost, weight, and reliability are critical issues. However, these inverters suffer from some safety and power quality drawbacks, such as common-mode voltage or ground leakage current issue between load and PV systems and dc current injection into the load.

The elimination of the output transformer from grid-connected photovoltaic (PV) systems not only reduces the cost, size, and weight of the conversion stage but also increases the system overall efficiency. However, if the transformer is removed, the galvanic isolation between the PV generator and the grid is lost. This may cause safety hazards in the event of ground faults. In addition, the circulation of leakage currents (common-mode currents) through the stray capacitance between the PV array and the ground would be enabled. Furthermore, when no transformer is used, the inverter could inject direct current (dc) to the grid, causing the saturation of the transformers along the distribution network. While safety requirements in transformerless systems can be met by means of external elements, leakage currents and the injection of dc into the grid must be guaranteed topologically or by the inverter's control system

The traditional full-bridge inverter with four active switches (H4 topology) is simple and has a good tradeoff between efficiency, complexity, and price. Its efficiency can reach 96%–97% with unipolar switching method. However, it generates a common-mode (CM) voltage with an amplitude of half input voltage at the switching frequency, which needs a big CM choke. This problem could be eliminated by the same H4 topology with bipolar switching method, but the efficiency is limited to 95.3% and requires a bigger output differential filter than that with unipolar modulation strategy. The parasitic capacitor between the PV array and the ground also plays an important role in a CM voltage or ground leakage current issue. The CM voltage across the capacitor generates a ground leakage current, which may cause severe electromagnetic interference (EMI) problem, load current distortion, and additional losses in the system, etc.

The stray capacitor depends on many factors, such as the PV panel and the frame structure, the surface of cells, the distance between cells, the module frame, the weather conditions, the humidity and the dust covering the PV pane, etc. For the crystalline silicon cells, 50- to 150-nF/kWp capacitance is expected, whereas for the thin-film cells, the capacitance up to 1 μ F/kWp is observed. Some standards, such as DIN VDE 0126-1-1, impose the disconnection of the inverter if the ground leakage current exceeds prefixed limits, as given in Table 1. By grounding the PV array, the parasitic capacitance and the associated hazardous current are reduced. Additionally, the type of transformerless topology and the applied switching scheme influence the magnitude and type of voltage fluctuation at the PV array with respect to the ground. Inverter topologies that are intrinsically safe from leakage currents are the half bridge (HB) and neutral-point-clamped ones. However, the need of twice input voltage than H4 topology and its input split capacitors are main drawbacks. Some efforts are also made to improve H4 topology and its corresponding PWM schemes.

TABLE 1.1 Leakage current RMS levels and corresponding disconnection times

Leakage current RMS values (mA)	Disconnect Time (s)
30	0.3
60	0.15
150	0.04

High performance inverters with H6-type configuration with hybrid modulation method is proposed and evaluated. The CM voltage and ground leakage current analysis based on the traditional H4 topology with both unipolar and bipolar modulation is also presented.

Manuscript received May 06, 2016

K.Venkata Ravindra, Assistant Professor, EEE Department, GIST, Nellore

N.Venkateswarlu, (M.Tech Student), EEE Department, GIST, Nellore

T.Ravi Kumar, Associated Professor, EEE Department, GIST, Nellore

II. COMMON MODE VOLTAGE AND LEAKAGE CURRENT ANALYSIS IN H4 TOPOLOGY

Without galvanic isolation between the grid and the PV system, the galvanic connection between them results in the appearances of a CM resonant circuit consisting of stray capacitance C_{pv} , representing the PV module to the ground and the filters, as shown in Fig. 1, where Z_{GcGg} is the series impedance between the ground connection points of the inverter and the load. Without filter and Z_{GcGg} considered.

For the CM voltage hot points located at inverter bridge middle points A and B, the instantaneous CM voltage and ground leakage current could be given by the following equation:

$$V_{cm} = \frac{V_{AN} + V_{BN}}{2} \quad (1)$$

$$i_{cm} = C_{pv} \frac{dV_{cm}}{dt} \quad (2)$$

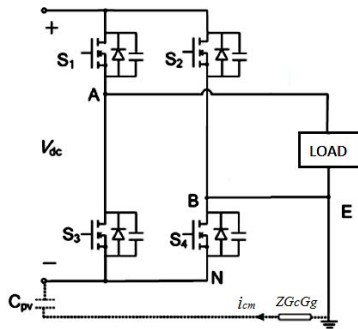

Fig. 1. Leakage current in H4 topology

Where V_{AN} and V_{BN} are the voltage between the branch midpoint and the dc bus minus terminal, respectively. It is easy to conclude that, if

$$V_{cm} = \frac{V_{AN} + V_{BN}}{2} = \text{constant} \quad (3)$$

A. H4 Topology With Bipolar Modulation

With the bipolar modulation scheme used in H4 topology, the diagonal switch pairs S1, S4 and S2, S3 are switched alternatively.

When S1, S4 are on,

$$V_{AN} = V_{DC}; V_{BN} = 0;$$

$$V_{cm} = \frac{V_{AN} + V_{BN}}{2} = \frac{V_{DC}}{2} \quad (4)$$

$$V_{AN} = 0; V_{BN} = V_{DC};$$

$$V_{cm} = \frac{V_{AN} + V_{BN}}{2} = \frac{V_{DC}}{2} \quad (5)$$

Consequently, V_{cm} is almost constant because V_{dc} is unchanged in steady mode. Thus, a small leakage current would appear. However, this modulation scheme is not well applied in practice due to large switching loss and large current ripple in the output.

B. H4 Topology With Unipolar Modulation

Unlike that with bipolar modulation, the H4 topology with unipolar modulation has two active switches, i.e., S2 and S4 that are only turned on/off in line with frequency. In addition, the other two switches, i.e., S1 and S3, are high-frequency switches. Thus, switching losses are decreased, and V_{AN} and V_{BN} are three-level voltages, which can improve the current ripple in the output inductors. Taking the positive half-cycle as an example, S4 is always on, and S1 switches at switching frequency f_s . When S1, S4 are on, the CM voltage is given by,

$$V_{AN} = V_{DC}; V_{BN} = 0;$$

$$V_{cm} = \frac{V_{AN} + V_{BN}}{2} = \frac{V_{DC}}{2} \quad (6)$$

When S1 is turned off and S4 is still on, the body diode of S3 naturally provides a freewheeling path, i.e.,

$$V_{AN} = 0; V_{BN} = 0;$$

$$V_{cm} = \frac{V_{AN} + V_{BN}}{2} = 0 \quad (7)$$

It is observed that the CM voltage changes between $V_{dc}/2$ and 0 at switching frequency f_s , which will produce a large CM current in the stray capacitance C_{pv} .

The H4 topology with bipolar modulation has an excellent CM characteristic but a poor DM performance. On the contrary, unipolar modulation improves its DM feature but decreases its CM property. A high-performance PV inverter topology should fulfil both CM and DM requirements.

III. H6 TOPOLOGY

The basic structure of H6 inverters has six switches (S1–S6) hence we call it as H6 inverters. A bipolar PWM H4 topology is the basic structure. An active switch S5 (or S6) and a passive diode D1 (or D2) establish a unidirectional cell, which is modulated with line frequency such as that in unipolar modulation. Two unidirectional cells are embedded in the middle point of the H4 inverter with different connection forms, which serve as freewheeling paths.

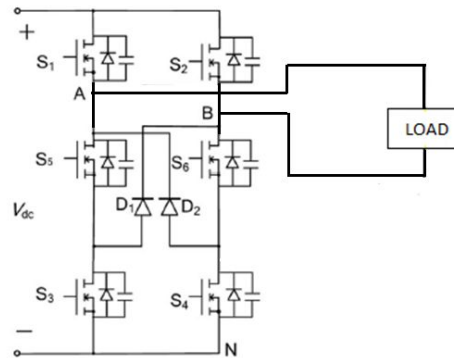

Fig.2. Existing H6 topology

Hybrid bridge topology as shown in fig.2, extra switches S5 and S6 are introduced in between the midpoint of the H4 inverter. It can be seen that there are two switches between the terminal (A) and the negative terminal of the PV and there are another two switches between the terminal (B) and the negative terminal of the PV. Therefore, the load

current is controlled to flow through three switches in the active modes of H6 type topology.

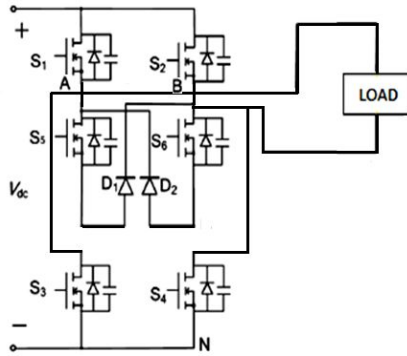

Fig.3. Proposed H6 topology

In order to reduce the conduction loss, of the collector of switch S3 is disconnected from the anode of diode D1, and then it is connected to the terminal (A) as shown in fig.3. As a result, the load current flows through S2 and S3 instead of S2, S3 and S5 in the active mode during the negative half cycle. The DC and AC sides of this topology are still disconnected in the freewheeling modes. The same means are applied to another leg, where the switch S4 is disconnected from the diode D2 and then connected to the terminal (B).

A. Modulation Strategy

Instead of inverting reference wave in unipolar modulation, carrier wave is inverting to get hybrid modulation. Switches pulses for hybrid modulation are generated as shown in fig.6.

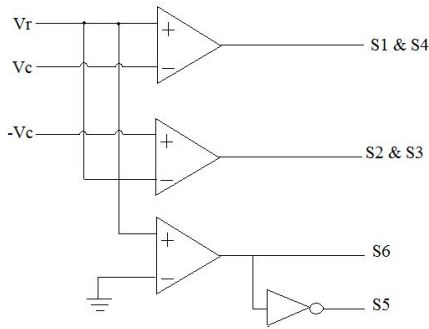

Fig.7. Hybrid modulation

The PWM scheme of the proposed H6 topology is presented here.

- (i) $V_r > 0$: S5 ON
- (ii) $V_r > V_c$: S1 & S4 ON
- (iii) $V_r < 0$: S6 ON
- (iv) $V_r < V_c$: S2 & S3 ON

B. Modes Of Operation

S.No	Positive Voltage (S6 is always on)		Negative Voltage (S5 is always ON)	
	Charging Mode	Freewheeling Mode	Charging Mode	Freewheeling Mode
1.	S1 & S4	S6 & D2	S2 & S3	S5 & D1

Modes of Operation	$V_{CM} = 0.5(V_{AN} + V_{BN})$		$VDM = V_{AN} - V_{BN}$	
	Charging	Freewheeling	Charging	Freewheeling
Positive half cycle	Vdc/2	Vdc/2	Vdc /2	0
Negative half cycle	Vdc/2	Vdc/2	-Vdc/2	0

C. Boost H6 Inverter

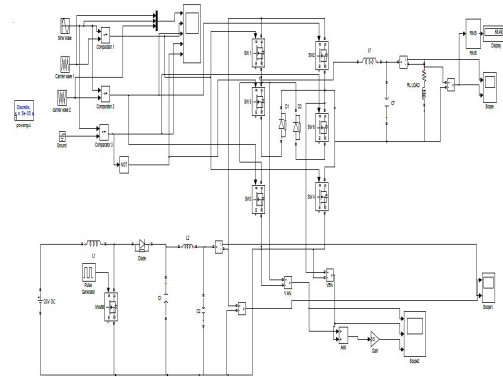

IV. SIMULATION RESULT

Table 2. System Parameters for H6 topology with Hybrid modulation

Parameter	Value
Input Voltage	70V
Modulation Index	0.8
Switching Frequency	3.2KHz
Load Value	R = 100Ω , L = 1mH
Filter	L1=2.55mH and C=4400μF

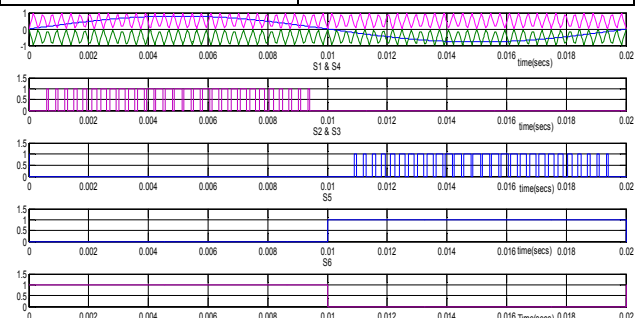

Fig 12. SPWM Waveform- H6 topology

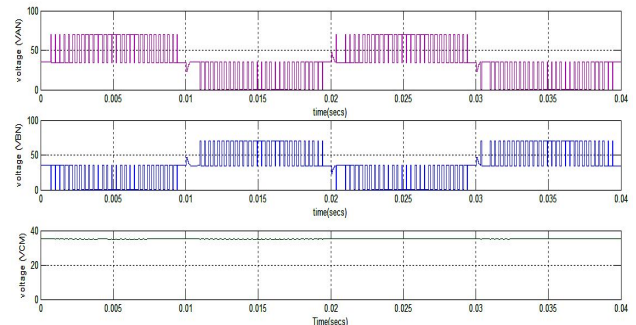

Fig .13. Common mode Voltage of H6 Topology

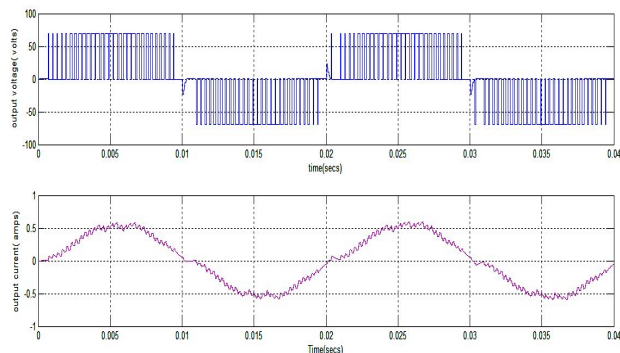

Fig.14. H6 topology without filter

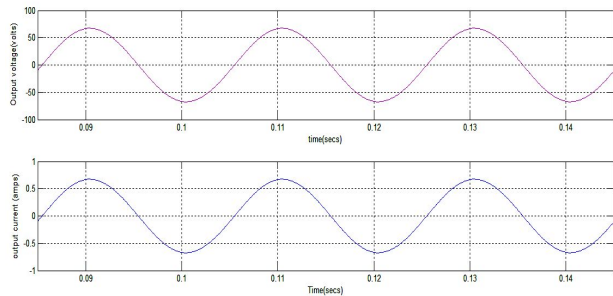

Fig.15. H6 topology with filter

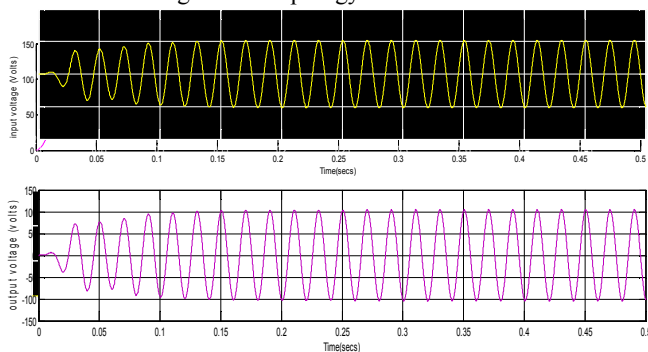

Fig16, Boost H6 inverter with filter

CONCLUSION

It highlights the common mode voltage or ground leakage current issue between load and PV systems and dc current injection into the load in transformerless inverter in conventional H4 topology. The above said issues lead to the introduction of H6 topology. The issue of common mode voltage and leakage current can be rectified by using H6 topology in hybrid modulation method.

Boost H6 inverter with hybrid modulation method and the performance is analyzed with H4 inverter with both Unipolar and Bipolar modulation method. Derivation rules of high-efficiency H6 inverters without leakage current issue have been analyzed. Unidirectional freewheeling cells are embedded in the middle point of the bipolar H4 inverter. Based on this concept, inverter topology derivation and standardizing is possible. Common-mode voltage and leakage current issues are eliminated in a nonisolated system with H6-type configuration without input split capacitors.

REFERENCE

- [1] J. M. Carrasco, L. G. Franquelo, J. T. Bialasiewicz, E. Galvan, R. C. P. Guisado, Ma. A. M. Prats, J. I. Leon, and N. Moreno-Alfonso, "Power-electronic systems for the grid integration of renewable energy sources: A survey," *IEEE Trans. Ind. Electron.*, vol. 53, no. 4, pp. 1002–1016, Jun. 2008.
- [2] M. C. Cavalcanti, A. M. Farias, K. C. de Oliveira, F. A. S. Neves, and J. L. Afonso, "Eliminating leakage currents in neutral point clamped inverters for photovoltaic systems," *IEEE Trans. Ind. Electron.*, vol. 59, no. 1, pp. 435–443, Jan 2012.
- [3] S. Aeaújo, P. Zacharias, and R. Mallwitz, "Highly efficient single-phase transformerless inverters for grid-connected photovoltaic systems," *IEEE Trans. Ind. Electron.*, vol. 57, no. 9, pp. 3118–3128, Sep. 2010.
- [4] T. Kerekes, G. Vazquez, R. Teodorescu, P. Rodriguez, and E. Aldabas, "A new high-efficiency single-phase transformerless PV inverter topology," *IEEE Trans. Ind. Electron.*, vol. 58, no. 1, pp. 184–191, Jan. 2011.
- [5] W. Yu, J.-S. Lai, H. Quian, and C. Hutchens, "High-efficiency MOSFET inverter with H6-type configuration for photovoltaic nonisolated AC-module applications," *IEEE Trans. Power Electron.*, vol. 26, no. 4, pp. 1253–1260, Apr. 2011.
- [6] M. C. Cavalcanti, K. C. de Oliveira, A. M. de Farias, F. A. S. Neves, G. M. S. Azevedo, and F. C. Camboim, "Modulation techniques to eliminate leakage currents in transformerless three-phase photovoltaic systems," *IEEE Trans. Ind. Electron.*, vol. 57, no. 4, pp. 1360–1368, Apr. 2010.
- [7] F. Bradaschia, M. C. Cavalcanti, P. E. P. Ferraz, F. A. S. Neves, E. C. dos Santos, and J. H. G. M. da Silva, "Modulation for three-phase transformerless Z-source inverter to reduce leakage currents in photovoltaic systems," *IEEE Trans. Ind. Electron.*, vol. 58, no. 12, pp. 5385–5395, Dec. 2011.
- [8] T. Nguyen and H. H. Lee, "Modulation strategies to reduce commonmode voltage for indirect matrix converters," *IEEE Trans. Ind. Electron.*, vol. 59, no. 1, pp. 129–140, Jan 2012.
- [9] Y. Jang and M. M. Jovanovic, "A bridgeless PFC boost rectifier with optimized magnetic utilization," *IEEE Trans. Power Electron.*, vol. 24, no. 1, pp. 85–93, Jan. 2009.
- [10] H. Qian, J.-S. Lai, and W. Yu, "Novel bidirectional ac–dc MOSFET converter for energy storage system applications," in *Proc. IEEE Energy Convers. Congr. Expo.*, Phoenix, AZ, Sep. 2011, pp. 3466–3471.
- [11] R.-Y. Kim, J.-S. Lai, B. York, and A. Koran, "Analysis and design of maximum power point tracking scheme for thermoelectric battery energy storage system," *IEEE Trans. Ind. Electron.*, vol. 56, no. 9, pp. 3709–3716, Sep. 2009.
- [12] N. Femia, G. Petrone, G. Spagnuolo, and M. Vitelli, "A technique for improving P&O MPPT performances of double-stage grid-connected photovoltaic systems," *IEEE Trans. Ind. Electron.*, vol. 56, no. 11, pp. 4473–4482, Nov. 2009.
- [13] I. Bratcu, I. Munteanu, S. Bacha, D. Picault, and B. Raison, "Cascaded DC–DC converter photovoltaic systems: Power optimization issues," *IEEE Trans. Ind. Electron.*, vol. 58, no. 2, pp. 403–411, Feb. 2011.
- [14] J. Wang, X. Lu, F. Zhang, and C. Gong, "Evaluation of input low frequency current ripple performance in front-end converter with single phase inverter load," in *Proc. IEEE WNWEC*, Nanjing, China, Sep. 2009, pp. 1–7.